

ZLH シリーズ
SERIES

105°C 小形化 長寿命 低インピーダンス品
105°C Miniaturized, Long Life, Low impedance.

◆特長/FEATURES

- ZLシリーズの耐久性向上と高容量化を実現し、更に高周波インピーダンスを低減。
Achieved endurance improvement and miniaturization of ZL series, as well as high frequency impedance reduction.
- 105°C 6000~10000時間品。
Load Life : 105°C 6000~10000hours.
- RoHS指令対応品。
RoHS compliance.

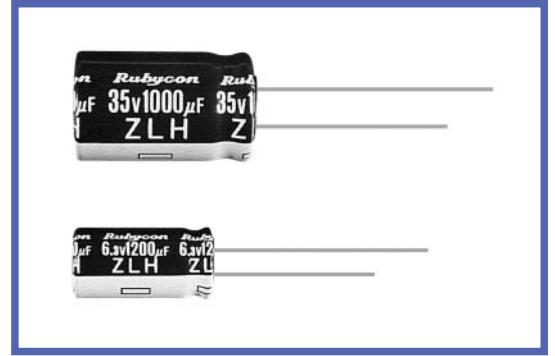

◆規格表/SPECIFICATIONS

項目 Items	特性 Characteristics																																	
カテゴリ温度範囲 Category Temperature Range	-40~+105°C																																	
定格電圧範囲 Rated Voltage Range	6.3~100V.DC																																	
静電容量許容差 Capacitance Tolerance	±20% (20°C, 120Hz)																																	
漏れ電流 Leakage Current(MAX)	I=0.01CV又は3µAのいずれか大なる値以下 (定格電圧印加2分後) I=0.01CV or 3µA whichever is greater. (After 2 minutes) I=漏れ電流(µA) Leakage Current C=定格静電容量(µF) Rated Capacitance V=定格電圧(V) Rated Voltage																																	
損失角の正接(tanδ) Dissipation Factor(MAX)	<table border="1"> <tr> <td>定格電圧(V) Rated Voltage</td> <td>6.3</td><td>10</td><td>16</td><td>25</td><td>35</td><td>50</td><td>63</td><td>80</td><td>100</td> <td>(20°C, 120Hz)</td> </tr> <tr> <td>tan δ</td> <td>0.22</td><td>0.19</td><td>0.16</td><td>0.14</td><td>0.12</td><td>0.10</td><td>0.09</td><td>0.08</td><td>0.08</td> <td></td> </tr> </table> <p>1000µFを越えるものは1000µF増す毎に上表の値に0.02を加えた値とする。 When rated capacitance is over 1000µF, tan δ shall be added 0.02 to the listed value with increase of every 1000µF.</p>	定格電圧(V) Rated Voltage	6.3	10	16	25	35	50	63	80	100	(20°C, 120Hz)	tan δ	0.22	0.19	0.16	0.14	0.12	0.10	0.09	0.08	0.08												
定格電圧(V) Rated Voltage	6.3	10	16	25	35	50	63	80	100	(20°C, 120Hz)																								
tan δ	0.22	0.19	0.16	0.14	0.12	0.10	0.09	0.08	0.08																									
耐久 Endurance	<p>105°C, 右表の時間定格電圧(リップル重畳)印加後、下記項目を満足すること。 After life test with rated ripple current at conditions stated in the table below, the capacitors shall meet the following requirements.</p> <table border="1"> <tr> <td>静電容量変化率 Capacitance Change</td> <td>初期値の±25%以内 (6.3V,10V: ±30%) Within ±25% of the initial value. (6.3V,10V: ±30%)</td> <td>ケースサイズ Case Size</td> <td>時間(hrs) Life Time</td> </tr> <tr> <td>損失角の正接 Dissipation Factor</td> <td>規格値の200%以下 Not more than 200% of the specified value.</td> <td>φD ≤ 6.3</td> <td>6000</td> </tr> <tr> <td>漏れ電流 Leakage Current</td> <td>規格値以下 Not more than the specified value.</td> <td>φD = 8</td> <td>8000</td> </tr> <tr> <td></td> <td></td> <td>φD ≥ 10</td> <td>10000</td> </tr> </table>	静電容量変化率 Capacitance Change	初期値の±25%以内 (6.3V,10V: ±30%) Within ±25% of the initial value. (6.3V,10V: ±30%)	ケースサイズ Case Size	時間(hrs) Life Time	損失角の正接 Dissipation Factor	規格値の200%以下 Not more than 200% of the specified value.	φD ≤ 6.3	6000	漏れ電流 Leakage Current	規格値以下 Not more than the specified value.	φD = 8	8000			φD ≥ 10	10000																	
静電容量変化率 Capacitance Change	初期値の±25%以内 (6.3V,10V: ±30%) Within ±25% of the initial value. (6.3V,10V: ±30%)	ケースサイズ Case Size	時間(hrs) Life Time																															
損失角の正接 Dissipation Factor	規格値の200%以下 Not more than 200% of the specified value.	φD ≤ 6.3	6000																															
漏れ電流 Leakage Current	規格値以下 Not more than the specified value.	φD = 8	8000																															
		φD ≥ 10	10000																															
低温特性 Low Temperature Stability (インピーダンス比) Impedance Ratio(MAX)	<table border="1"> <tr> <td>定格電圧(V) Rated Voltage</td> <td>6.3</td><td>10</td><td>16</td><td>25</td><td>35</td><td>50</td><td>63</td><td>80</td><td>100</td> <td>(120Hz)</td> </tr> <tr> <td>Z(-25°C)/Z(20°C)</td> <td>2</td><td>2</td><td>2</td><td>2</td><td>2</td><td>2</td><td>2</td><td>2</td><td>2</td> <td></td> </tr> <tr> <td>Z(-40°C)/Z(20°C)</td> <td>3</td><td>3</td><td>3</td><td>3</td><td>3</td><td>3</td><td>3</td><td>3</td><td>3</td> <td></td> </tr> </table>	定格電圧(V) Rated Voltage	6.3	10	16	25	35	50	63	80	100	(120Hz)	Z(-25°C)/Z(20°C)	2	2	2	2	2	2	2	2	2		Z(-40°C)/Z(20°C)	3	3	3	3	3	3	3	3	3	
定格電圧(V) Rated Voltage	6.3	10	16	25	35	50	63	80	100	(120Hz)																								
Z(-25°C)/Z(20°C)	2	2	2	2	2	2	2	2	2																									
Z(-40°C)/Z(20°C)	3	3	3	3	3	3	3	3	3																									

◆リップル電流補正係数/
MULTIPLIER FOR RIPPLE CURRENT
周波数係数 Frequency coefficient

周波数(Hz) Frequency	120	1k	10k	100k ≤
8.2~33µF	0.42	0.70	0.90	1.00
47~270µF	0.50	0.73	0.92	1.00
330~680µF	0.55	0.77	0.94	1.00
820~1800µF	0.60	0.80	0.96	1.00
2200~8200µF	0.70	0.85	0.98	1.00

◆寸法図/DIMENSIONS (mm)

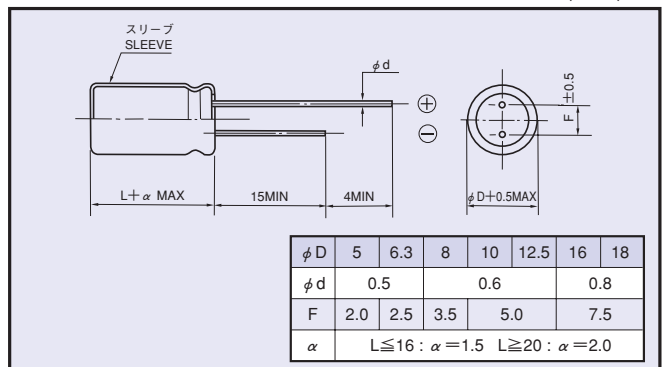

◆呼称方法/PART NUMBER

ZLH D X L
 定格電圧 シリーズ名 定格静電容量 静電容量許容差 副記号 リード加工記号 ケースサイズ
 Rated Voltage Series Rated Capacitance Capacitance Tolerance Option Lead Forming Case Size

◆標準品一覧表 / STANDARD SIZE

定格電圧 Rated Voltage (V・DC)	定格静電容量 Rated capacitance (μF)	外形寸法 Size φ D×L(mm)	定格リップル電流 Rated ripple current (mA r.m.s./105°C, 100kHz)	インピーダンス(Ω MAX) Impedance	
				20°C, 100kHz	-10°C, 100kHz
6.3 (0J)	220	5×11	345	0.22	0.80
	470	6.3×11	540	0.094	0.35
	820	8×11.5	945	0.056	0.19
	1200	8×16	1250	0.045	0.15
	1200	10×12.5	1330	0.039	0.14
	1500	8×20	1500	0.029	0.11
	1800	10×16	1760	0.028	0.10
	2200	10×20	1960	0.020	0.06
	2700	10×23	2250	0.018	0.054
	3900	12.5×20	2480	0.017	0.043
	4700	12.5×25	2900	0.015	0.038
	5600	12.5×30	3450	0.013	0.033
	6800	16×20	3250	0.015	0.038
	6800	12.5×35	3570	0.012	0.031
8200	16×25	3630	0.013	0.035	
10 (1A)	150	5×11	345	0.22	0.80
	330	6.3×11	540	0.094	0.35
	680	8×11.5	945	0.056	0.19
	1000	8×16	1250	0.045	0.15
	1000	10×12.5	1330	0.039	0.14
	1500	8×20	1500	0.029	0.11
	1500	10×16	1760	0.028	0.10
	1800	10×20	1960	0.020	0.060
	2200	10×23	2250	0.018	0.054
	3300	12.5×20	2480	0.017	0.043
	3900	12.5×25	2900	0.015	0.038
	4700	12.5×30	3450	0.013	0.033
	4700	16×20	3250	0.015	0.038
	5600	12.5×35	3570	0.012	0.031
6800	16×25	3630	0.013	0.035	
16 (1C)	100	5×11	345	0.22	0.80
	220	6.3×11	540	0.094	0.35
	470	8×11.5	945	0.056	0.19
	680	8×16	1250	0.045	0.15
	680	10×12.5	1330	0.039	0.14
	1000	8×20	1500	0.029	0.11
	1000	10×16	1760	0.028	0.10
	1500	10×20	1960	0.020	0.060
	1800	10×23	2250	0.018	0.054
	2200	12.5×20	2480	0.017	0.043
	2700	12.5×25	2900	0.015	0.038
	3300	12.5×30	3450	0.013	0.033
	3300	16×20	3250	0.015	0.038
	3900	12.5×35	3570	0.012	0.031
4700	16×25	3630	0.013	0.035	
25 (1E)	68	5×11	345	0.22	0.80
	150	6.3×11	540	0.094	0.35
	330	8×11.5	945	0.056	0.19
	390	8×16	1250	0.045	0.15
	470	10×12.5	1330	0.039	0.14
	560	8×20	1500	0.029	0.11
	680	10×16	1760	0.028	0.10
	820	10×20	1960	0.020	0.060
	1000	10×23	2250	0.018	0.054
	1500	12.5×20	2480	0.017	0.043
	1800	12.5×25	2900	0.015	0.038
	2200	12.5×30	3450	0.013	0.033
	2200	16×20	3250	0.015	0.038
	2700	12.5×35	3570	0.012	0.031
3300	16×25	3630	0.013	0.035	
35 (1V)	47	5×11	345	0.22	0.80
	100	6.3×11	540	0.094	0.35
	220	8×11.5	945	0.056	0.19
	270	8×16	1250	0.045	0.15
	330	10×12.5	1330	0.039	0.14
	390	8×20	1500	0.029	0.11
	470	10×16	1760	0.028	0.10
	560	10×20	1960	0.020	0.060
	680	10×23	2250	0.018	0.054
	1000	12.5×20	2480	0.017	0.043
	1200	12.5×25	2900	0.015	0.038
	1500	12.5×30	3450	0.013	0.033
	1500	16×20	3250	0.015	0.038
	1800	12.5×35	3570	0.012	0.031
2200	16×25	3630	0.013	0.035	
50 (1H)	27	5×11	238	0.34	1.18
	56	6.3×11	385	0.14	0.50
	100	8×11.5	724	0.074	0.22
	120	8×16	950	0.061	0.18
	150	10×12.5	979	0.061	0.18
	180	8×20	1190	0.046	0.14
	220	10×16	1370	0.042	0.12
	270	10×20	1580	0.030	0.090
	330	10×23	1870	0.028	0.085
	470	12.5×20	2050	0.027	0.068
	560	12.5×25	2410	0.023	0.059
	680	12.5×30	2860	0.021	0.052
	820	12.5×35	2960	0.019	0.051
	820	16×20	2730	0.023	0.059
1000	16×25	3010	0.021	0.056	

◆標準品一覧表 / STANDARD SIZE

定格電圧 Rated Voltage (V・DC)	定格静電容量 Rated capacitance (μF)	外形寸法 Size φ D×L(mm)	定格リップル電流 Rated ripple current (mA r.m.s./105°C, 100kHz)	インピーダンス(Ω MAX) Impedance	
				20°C, 100kHz	-10°C, 100kHz
63 (1J)	18	5×11	173	0.88	3.5
	47	6.3×11	278	0.35	1.4
	82	8×11.5	525	0.22	0.88
	100	8×16	688	0.16	0.64
	120	10×12.5	725	0.15	0.60
	150	8×20	861	0.12	0.48
	180	10×16	998	0.11	0.44
	270	10×20	1200	0.078	0.31
	270	12.5×16	1200	0.082	0.27
	330	10×23	1410	0.069	0.28
	390	12.5×20	1570	0.060	0.19
	470	12.5×25	1990	0.043	0.14
	560	12.5×30	2410	0.035	0.13
	560	16×20	2100	0.043	0.14
	680	12.5×35	2620	0.033	0.11
	820	12.5×40	2940	0.027	0.090
	820	16×25	2730	0.032	0.096
	820	18×20	2500	0.038	0.10
	1200	16×31.5	2990	0.024	0.068
	1200	18×25	2800	0.031	0.084
1500	16×35.5	3040	0.021	0.057	
1500	18×31.5	3300	0.025	0.068	
1800	16×40	3570	0.019	0.057	
1800	18×35.5	3570	0.020	0.054	
2200	18×40	3670	0.018	0.049	
80 (1K)	12	5×11	163	1.4	5.6
	33	6.3×11	267	0.57	2.3
	56	8×11.5	462	0.36	1.4
	68	8×16	585	0.25	1.0
	82	10×12.5	624	0.23	0.96
	100	8×20	735	0.19	0.76
	120	10×16	780	0.17	0.72
	180	10×20	1040	0.12	0.52
	180	12.5×16	975	0.13	0.43
	220	10×23	1170	0.11	0.47
	270	12.5×20	1430	0.085	0.31
	330	12.5×25	1620	0.060	0.23
	390	12.5×30	1950	0.051	0.21
	390	16×20	1750	0.058	0.21
	470	12.5×35	2140	0.043	0.17
	560	12.5×40	2340	0.036	0.15
	560	16×25	2210	0.044	0.16
	560	18×20	1950	0.054	0.18
	680	16×31.5	2400	0.033	0.12
	820	16×35.5	2600	0.029	0.10
820	18×25	2270	0.038	0.13	
1000	16×40	2860	0.027	0.090	
1000	18×31.5	2470	0.031	0.11	
1200	18×35.5	2860	0.027	0.084	
1500	18×40	3510	0.026	0.076	

定格電圧 Rated Voltage (V・DC)	定格静電容量 Rated capacitance (μF)	外形寸法 Size φ D×L(mm)	定格リップル電流 Rated ripple current (mA r.m.s./105°C, 100kHz)	インピーダンス(Ω MAX) Impedance	
				20°C, 100kHz	-10°C, 100kHz
100 (2A)	8.2	5×11	163	1.4	5.6
	18	6.3×11	267	0.57	2.3
	33	8×11.5	462	0.36	1.4
	47	8×16	585	0.25	1.0
	56	10×12.5	624	0.23	0.96
	68	8×20	735	0.19	0.76
	82	10×16	780	0.17	0.72
	100	10×20	1040	0.12	0.52
	100	12.5×16	975	0.13	0.43
	120	10×23	1170	0.11	0.47
	150	12.5×20	1430	0.085	0.31
	220	12.5×25	1620	0.060	0.23
	270	12.5×30	1950	0.051	0.21
	270	16×20	1750	0.058	0.21
	330	12.5×35	2140	0.043	0.17
	390	12.5×40	2340	0.036	0.15
	390	16×25	2210	0.044	0.16
	390	18×20	1950	0.054	0.18
	470	16×31.5	2400	0.033	0.12
	470	18×25	2270	0.038	0.13
560	16×35.5	2600	0.029	0.10	
560	18×31.5	2470	0.031	0.11	
680	16×40	2860	0.027	0.090	
680	18×35.5	2860	0.027	0.084	
820	18×40	3510	0.026	0.076	